

ASSEMBLY INSTRUCTIONS

MODEL : QEK-0269
FTVCYAWM220907WN

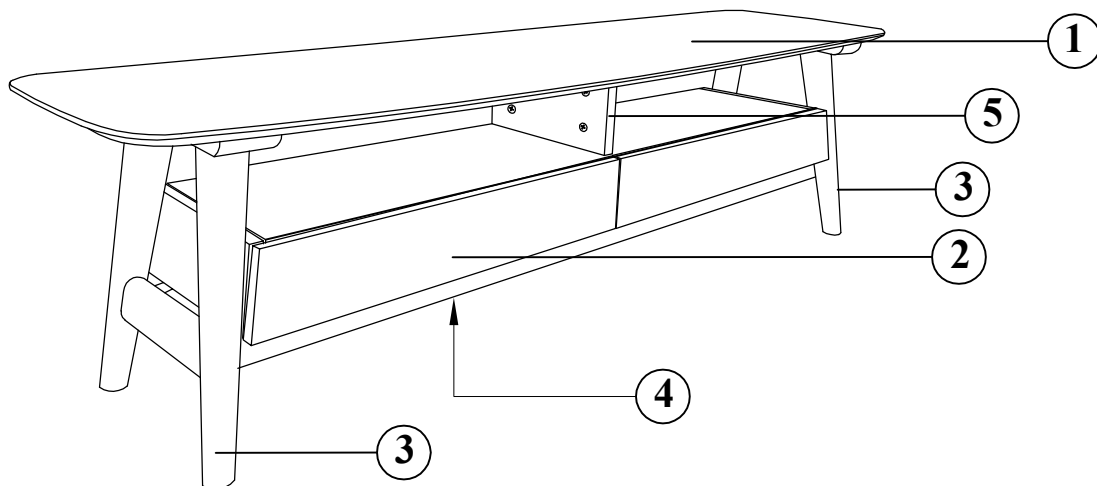





**COMPLETE ASSEMBLY**

THANK YOU FOR PURCHASING THIS QUALITY PRODUCT. BE SURE TO CHECK ALL PACKING MATERIAL CAREFULLY FOR SMALL PARTS WHICH MAY HAVE COME LOOSE INSIDE THE CARTON DURING THE SHIPMENT. SEPARATE, IDENTIFY AND COUNT ALL PARTS AND METAL HARDWARE, COMPARE WITH THE PARTS LISTS BELOW TO BE SURE ALL PARTS ARE PRESENT.

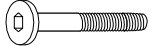
PART LIST

CODE	DESCRIPTION	QTY.
1	TABLE TOP	1 PC
2	DRAWER BOX	1 SET
3	SIDE MEMBER LEFT&RIGHT	2 PCS
4	RAIL	2 PCS
5	CENTER PANEL (UP)	1 PC

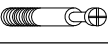
HARDWARE LIST

CODE	DESCRIPTION	QTY.
A	 ALLEN KEY M4 X 110MM	1 PC
B	 JCBC BOLT M6 X 50MM	4 PCS
C	 JCBC BOLT M6 X 30MM	16 PCS
D	 SPRING WASHER 1/4"	20 PCS
E	 FLAT WASHER M6 X 13MM	20 PCS
F	 MINIFIX BOLT (262.28.571)	4 PCS
G	 MINIFIX NUT (262.26.648)	4 PCS

ASSEMBLY INSTRUCTIONS
MODEL : QEK-0269
FTVCYAWM220907WN

STEP 1

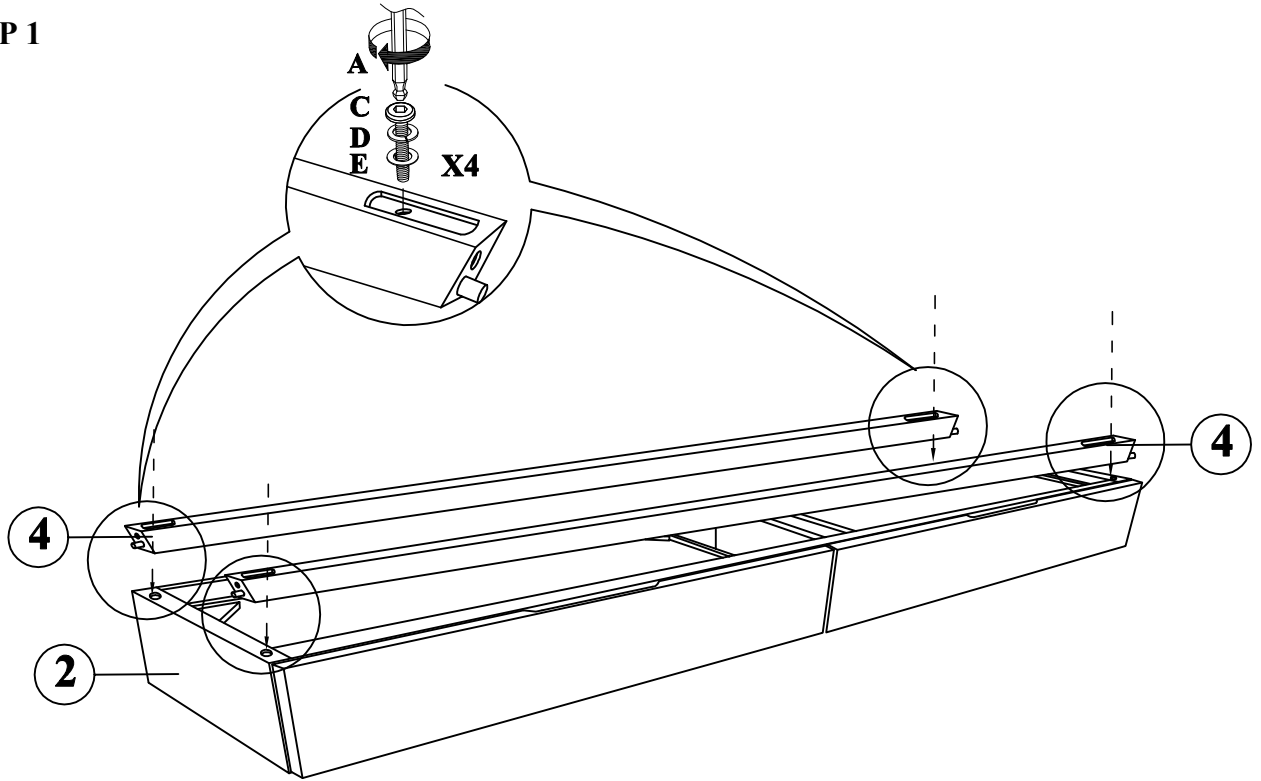

STEP 2

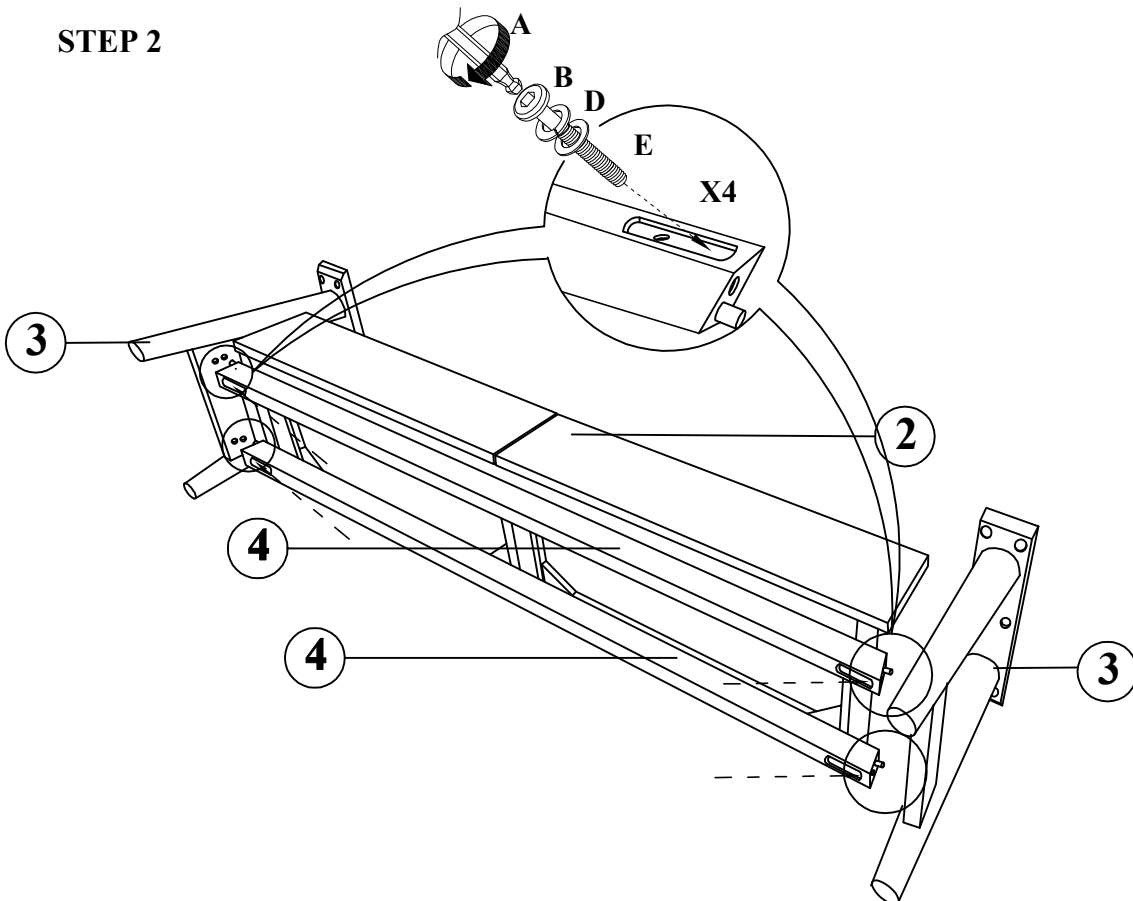

ASSEMBLY INSTRUCTIONS
MODEL : QEK-0269
FTVCYAWM220907WN

STEP 3

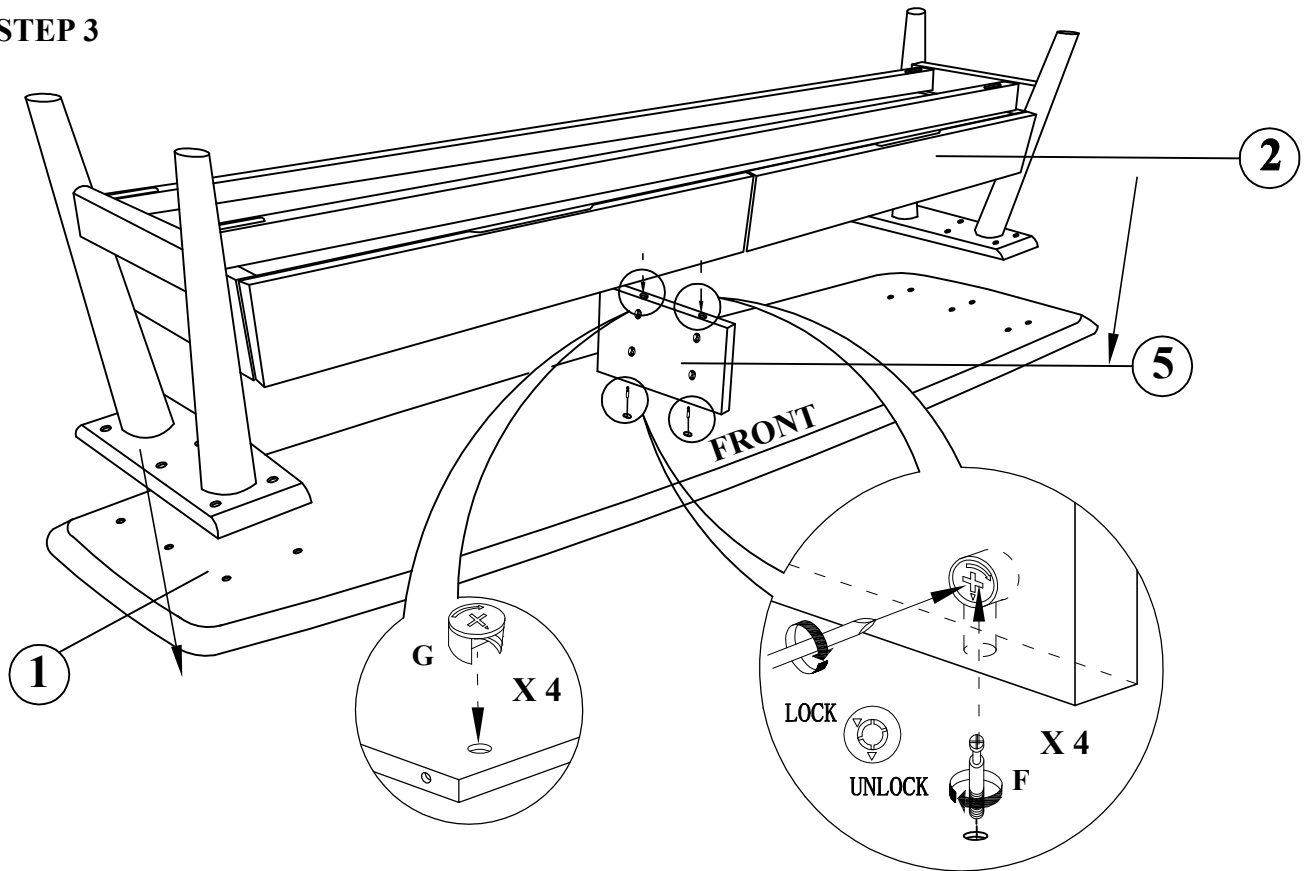

STEP 4

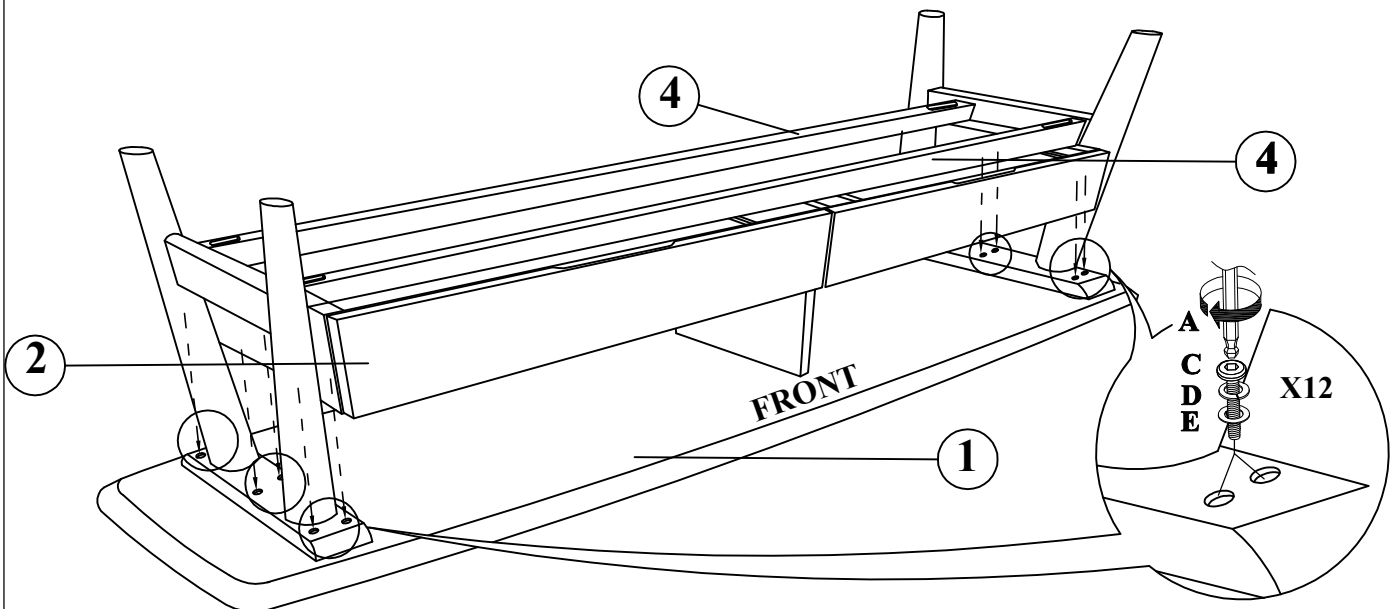

ASSEMBLY INSTRUCTIONS
MODEL : QEK-0269
FTVCYAWM220907WN

STEP 5

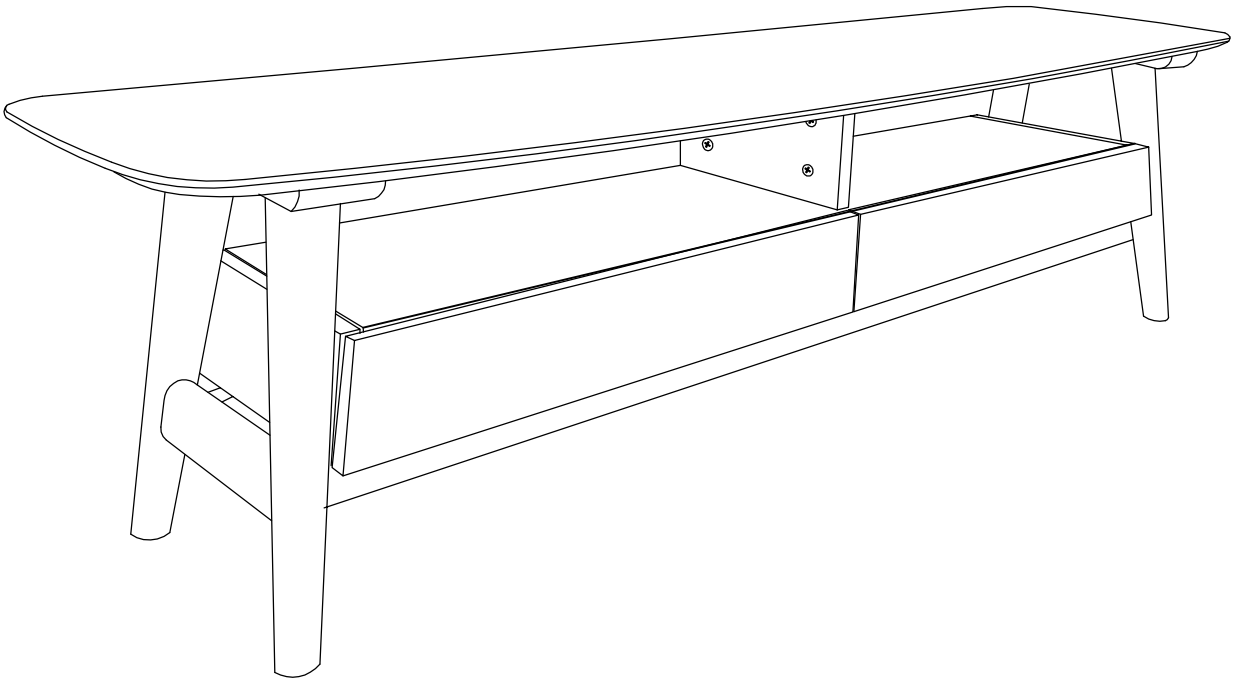

COMPLETE ASSEMBLY