

# ASSEMBLY INSTRUCTIONS

**MODEL : CDK-1217  
FDTSYAWM220901CC**

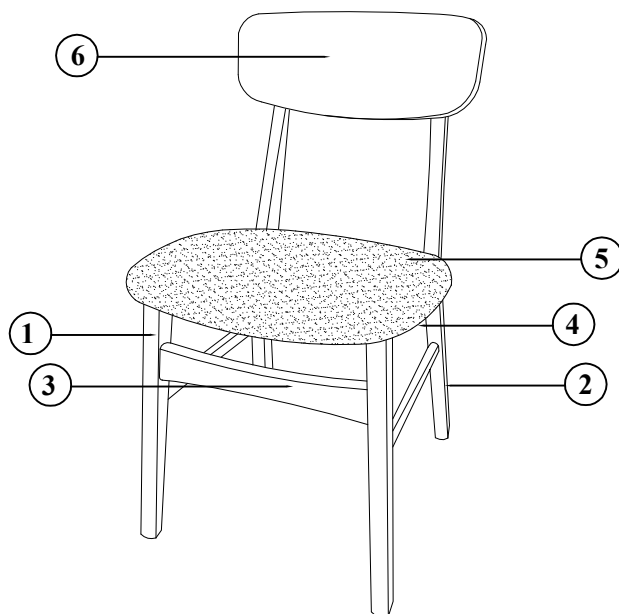





## COMPLETE ASSEMBLY

THANK YOU FOR PURCHASING THIS QUALITY PRODUCT. BE SURE TO CHECK ALL PACKING MATERIAL CAREFULLY FOR SMALL PARTS WHICH MAY HAVE COME LOOSE INSIDE THE CARTON DURING THE SHIPMENT. SEPARATE, IDENTIFY AND COUNT ALL PARTS AND METAL HARDWARE, COMPARE WITH THE PARTS LISTS BELOW TO BE SURE ALL PARTS ARE PRESENT.

### PART LIST

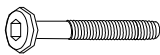
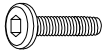
CODE	DESCRIPTION	QTY.
1	SIDE MEMBER (RIGHT)	1 PC
2	SIDE MEMBER (LEFT)	1 PC
3	FRONT PANEL (LONG)	1 PC
4	BACK PANEL (SHORT)	1 PC
5	SEAT	1 PC
6	BACK REST	1 PC

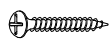
### HARDWARE LIST

CODE	DESCRIPTION	QTY.
A	 ALLEN KEY M4 X 110MM	1 PC
B	 JCBC BOLT M6 X 50MM	4 PCS
C	 JCBC BOLT M6 X 30MM	4 PCS
D	 SPRING WASHER 1/4"	8 PCS
E	 FLAT WASHER M6 X 13MM	8 PCS
F	 PAN HEAD CBS #8 x 1 1/4"	4 PCS
G	 DOWEL PIN M8 x 30MM	2 PCS

TOOL REQUIRED (NOT INCLUDED) :

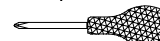

**NOTE : QUANTITIES SHOWN ARE FOR ONE CHAIR**

# ASSEMBLY INSTRUCTIONS

MODEL : CDK-1217

FDTSYAWM220901CC

## STEP 1

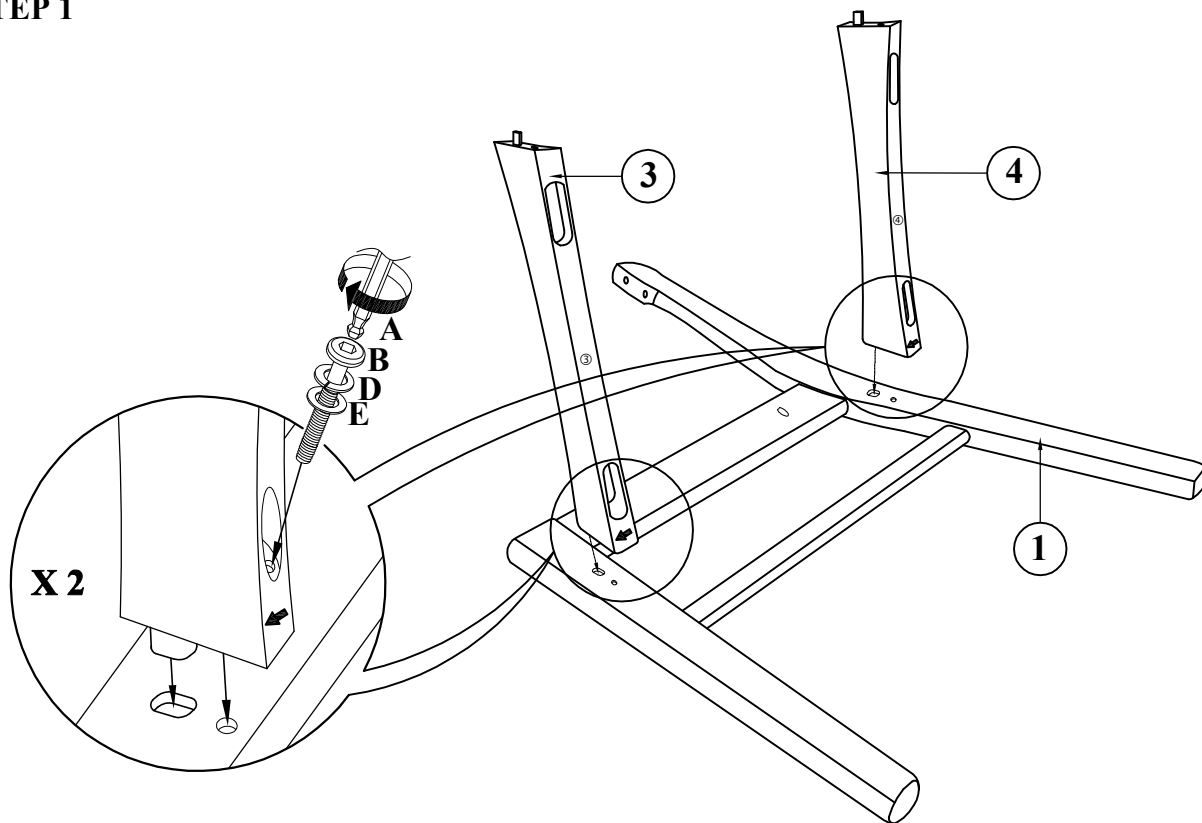

## STEP 2

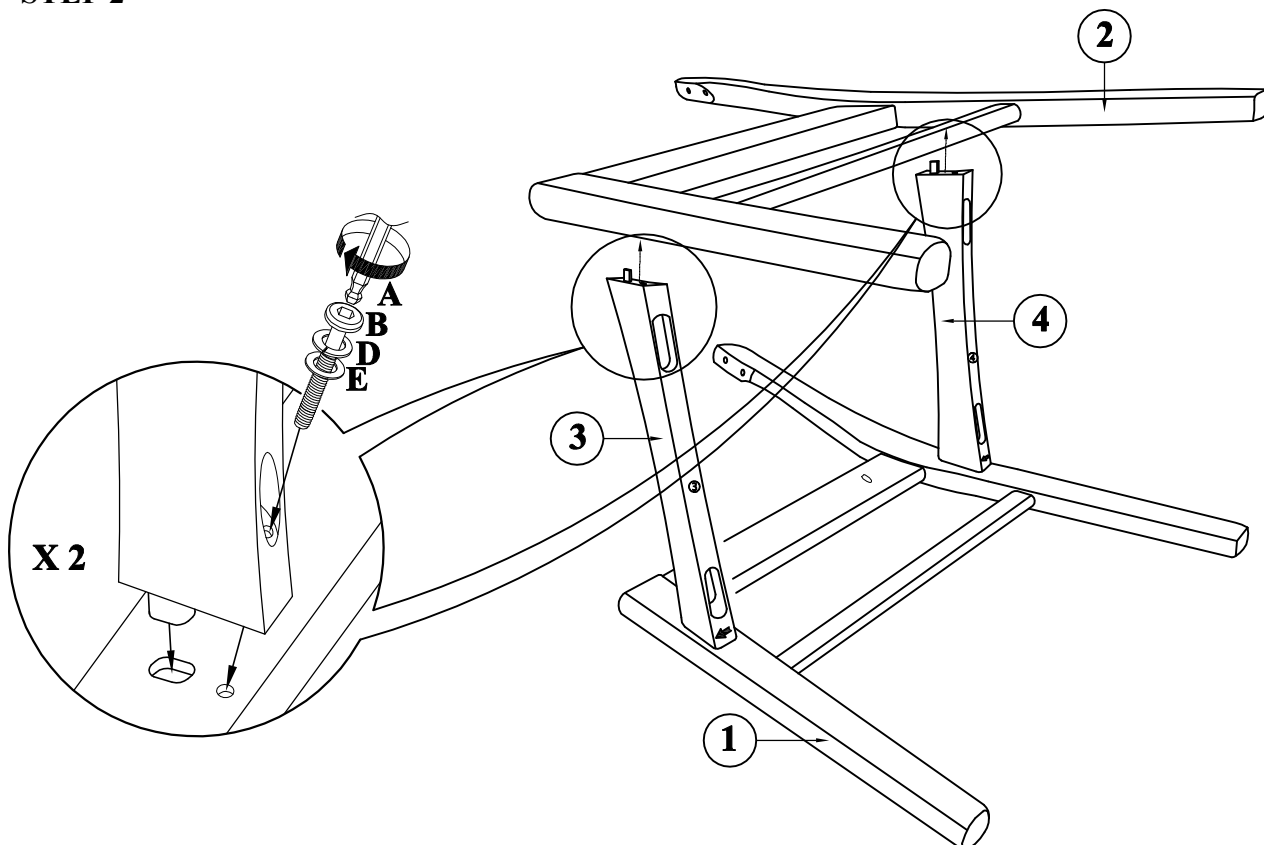

# ASSEMBLY INSTRUCTIONS

MODEL : CDK-1217

FDTSYAWM220901CC

## STEP 3

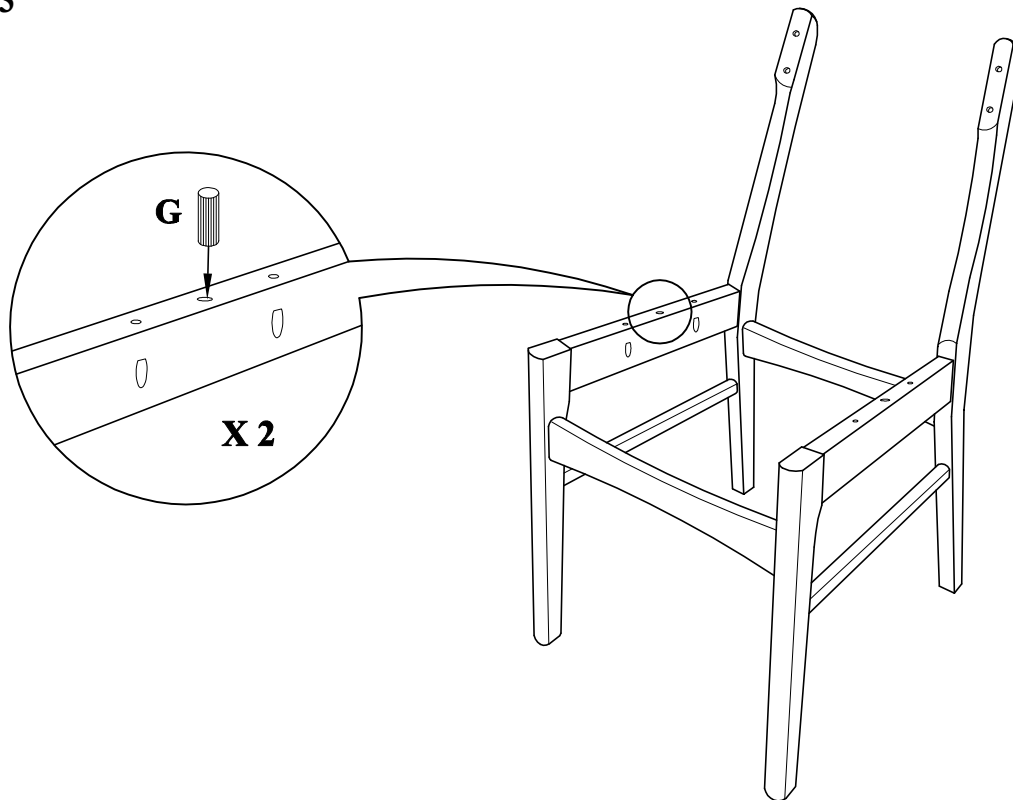

## STEP 4

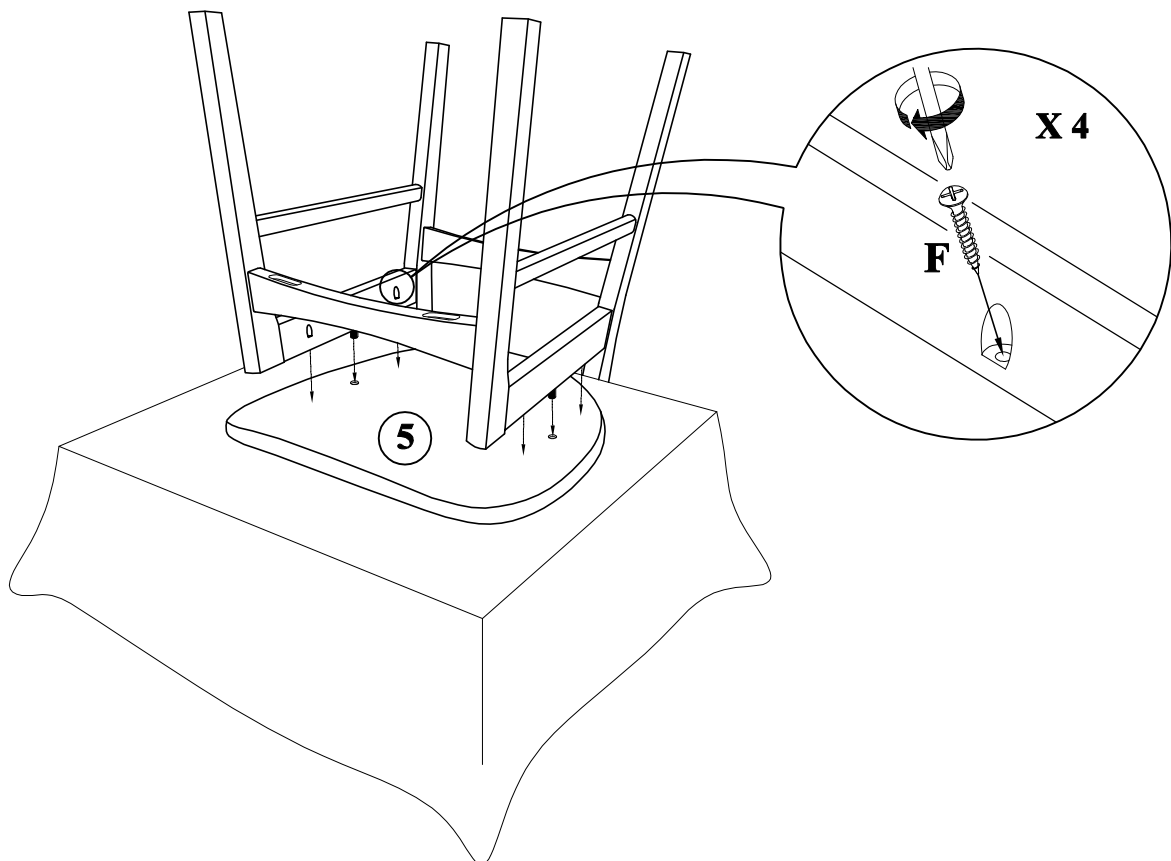

# ASSEMBLY INSTRUCTIONS

MODEL : CDK-1217

FDTSYAWM220901CC

## STEP 5

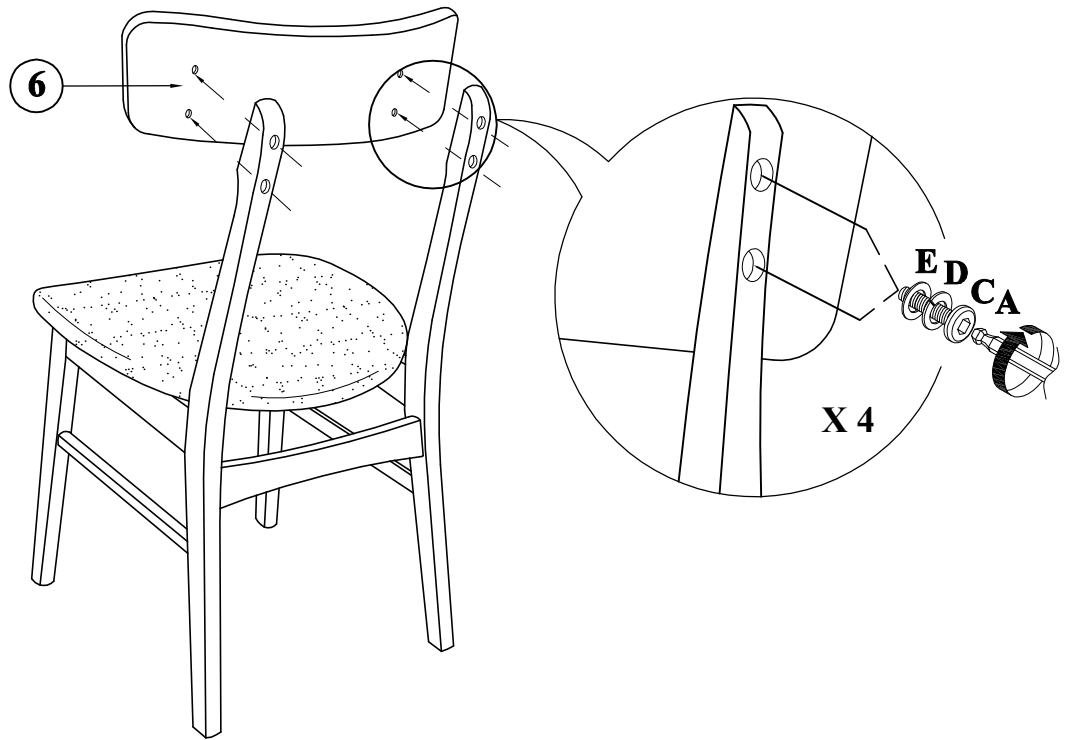

## STEP 6

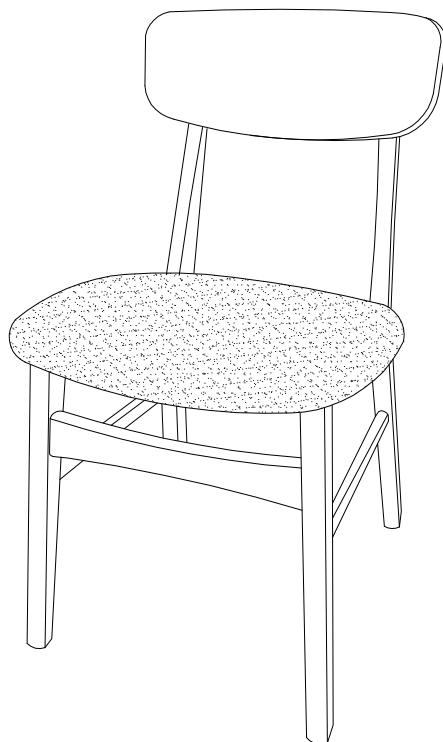

# ASSEMBLY INSTRUCTIONS

**MODEL : TDB-1556**  
**FDTSYAWM220901CC**

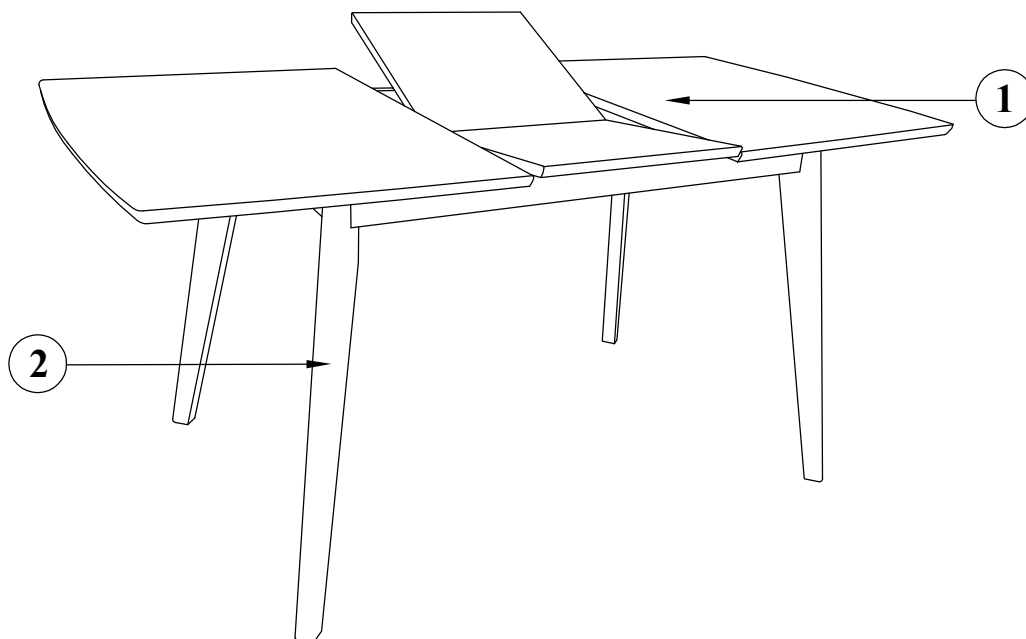





## COMPLETE ASSEMBLY

THANK YOU FOR PURCHASING THIS QUALITY PRODUCT. BE SURE TO CHECK ALL PACKING MATERIAL CAREFULLY FOR SMALL PARTS WHICH MAY HAVE COME LOOSE INSIDE THE CARTON DURING THE SHIPMENT. SEPARATE, IDENTIFY AND COUNT ALL PARTS AND METAL HARDWARE, COMPARE WITH THE PARTS LISTS BELOW TO BE SURE ALL PARTS ARE PRESENT.

### PART LIST

CODE	DESCRIPTION	QTY.
1	TABLE TOP	1 PC
2	TABLE LEG	4 PCS

### HARDWARE LIST

CODE	DESCRIPTION	QTY.
A	 ALLEN KEY M4 X 63MM	1 PC
B	 JCBC BOLT M6 X 60MM	8 PCS
C	 SPRING WASHER 1/4"	8 PCS
D	 FLAT WASHER 5/16"	8 PCS

TOOL REQUIRED (NOT INCLUDED) :

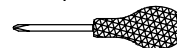

# ASSEMBLY INSTRUCTIONS

## MODEL : TDB-1556

### FDTSYAWM220901CC

#### STEP 1

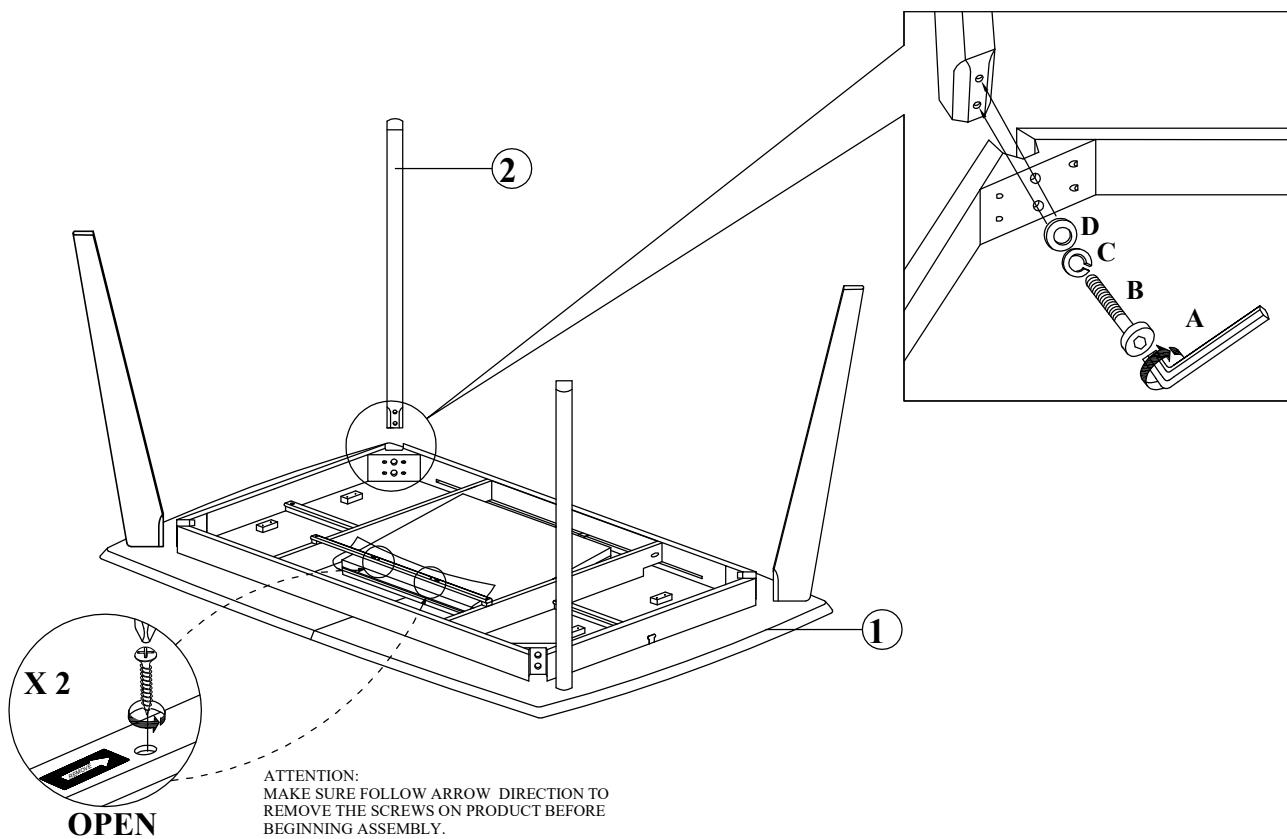

#### STEP 2

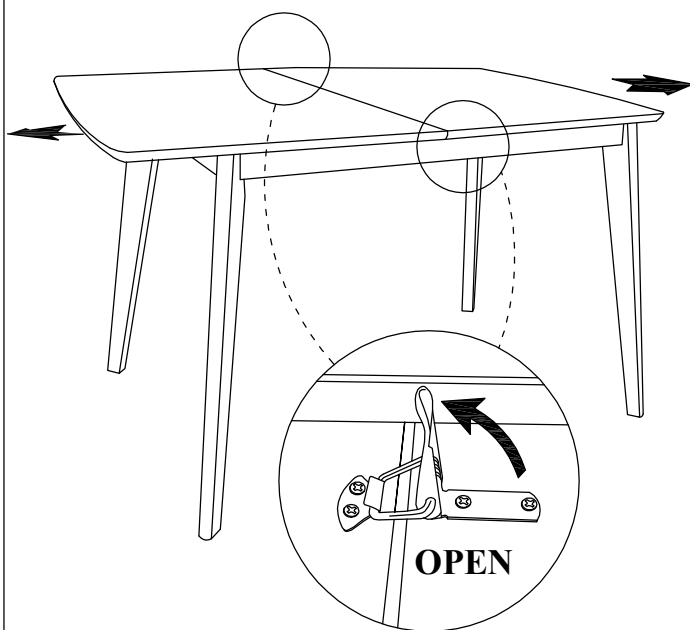

#### STEP 3

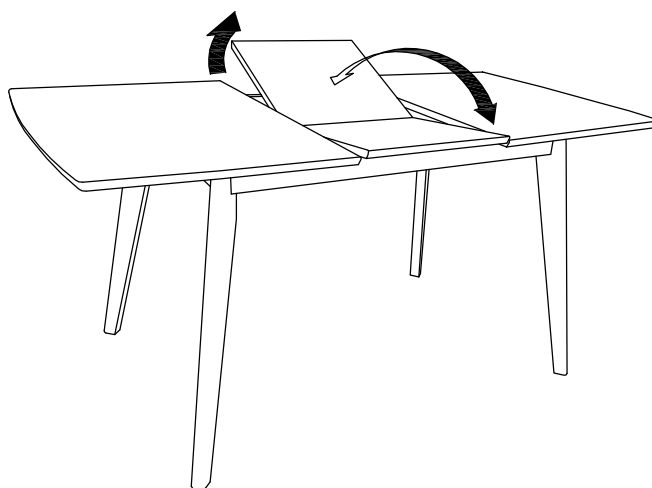

ASSEMBLY INSTRUCTIONS  
MODEL : TDB-1556  
FDTSYAWM220901CC

**STEP 4**

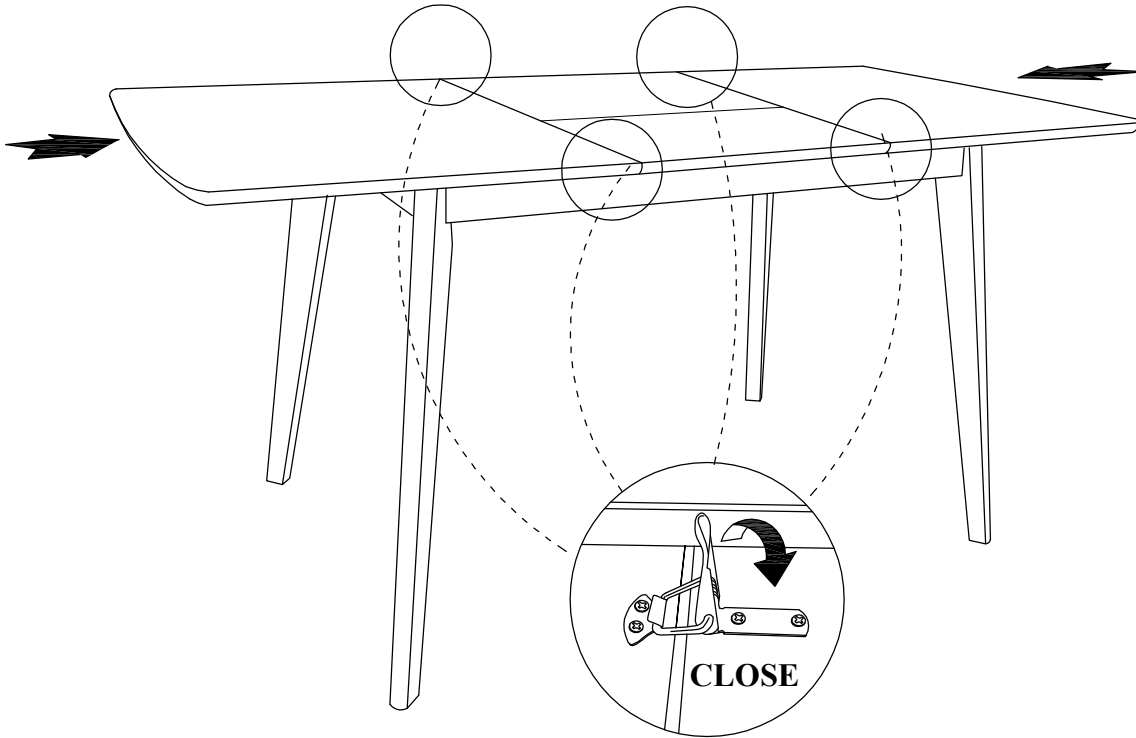

**STEP 5**

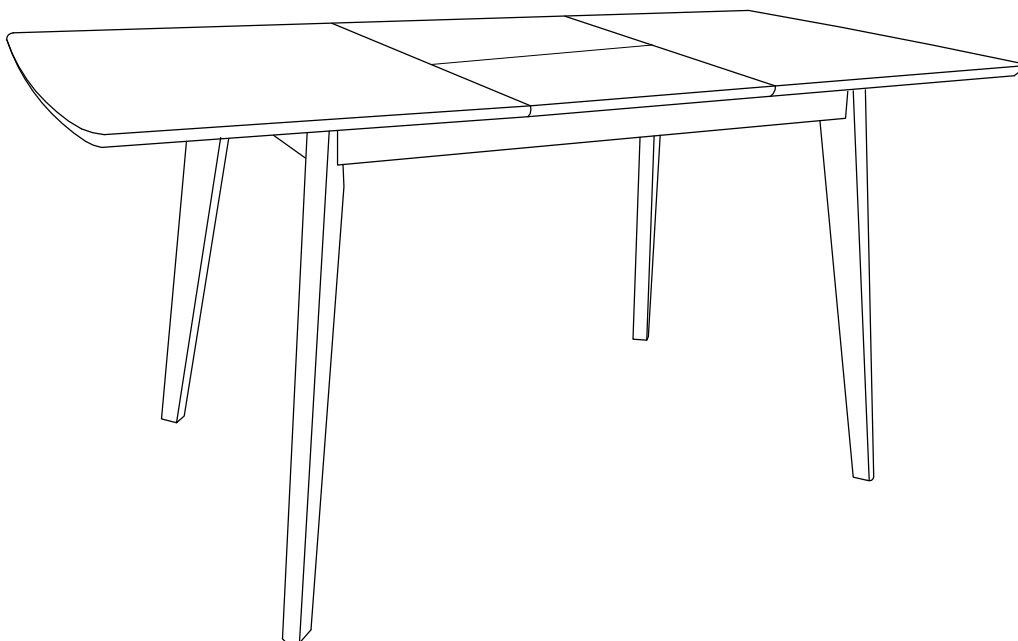

**ASSEMBLY INSTRUCTIONS**

**MODEL : CHK-1024**  
**FDTSYAWM220901CC**

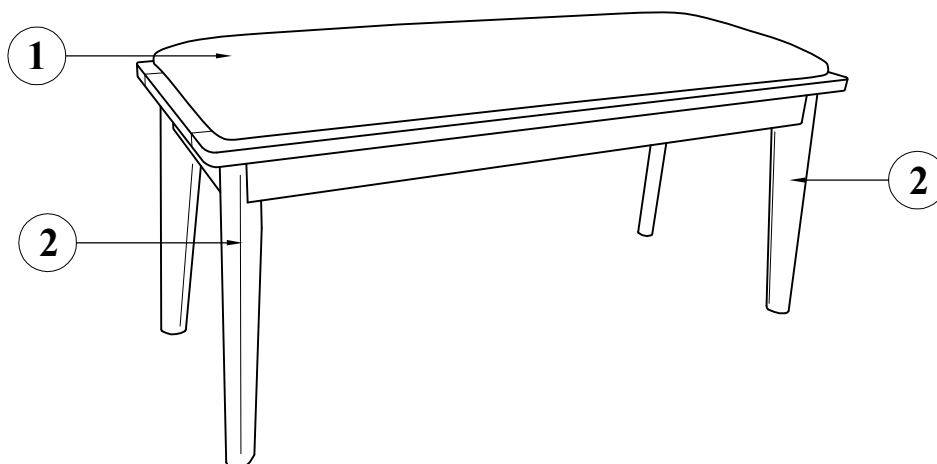



**THANK YOU FOR PURCHASING THIS QUALITY PRODUCT. BE SURE TO CHECK ALL PACKING MATERIAL CAREFULLY FOR SMALL PARTS WHICH MAY HAVE COME LOOSE INSIDE THE CARTON DURING THE SHIPMENT. SEPARATE, IDENTIFY AND COUNT ALL PARTS AND METAL HARDWARE, COMPARE WITH THE PARTS LISTS BELOW TO BE SURE ALL PARTS ARE PRESENT.**

**PART LIST**

CODE	DESCRIPTION	QTY.
1	WOODEN SEAT W/APRON	1 SET
2	CHAIR LEG	4 PCS

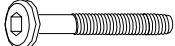
**HARDWARE LIST**

CODE	DESCRIPTION	QTY.
<b>A</b>	 ALLEN KEY M4 X 63MM	1 PC
<b>B</b>	 JCBC BOLT M6 X 60MM	8 PCS
<b>C</b>	 SPRING WASHER 1/4"	8 PCS
<b>D</b>	 FLAT WASHER 1/4"	8 PCS



**ASSEMBLY INSTRUCTIONS**  
**MODEL : CHK-1024**  
**FDTSYAWM220901CC**

**STEP 1**

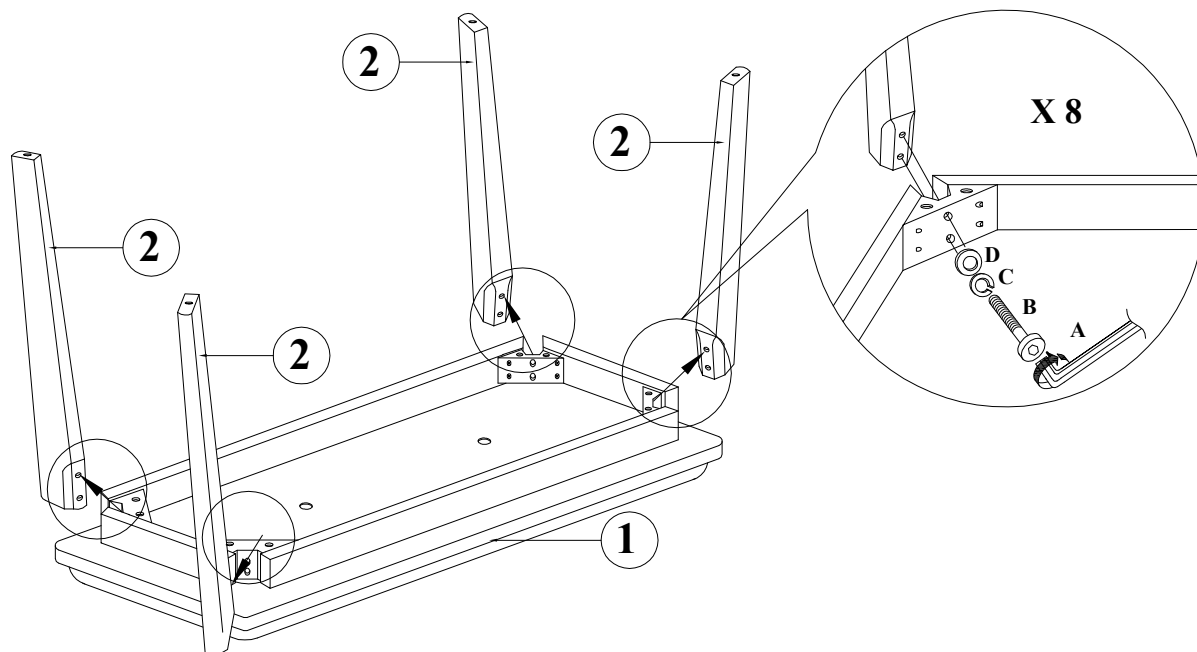

**STEP 2**

