

ASSEMBLY INSTRUCTIONS

MODEL :TLF-1718
FCSCYAWM220905WN

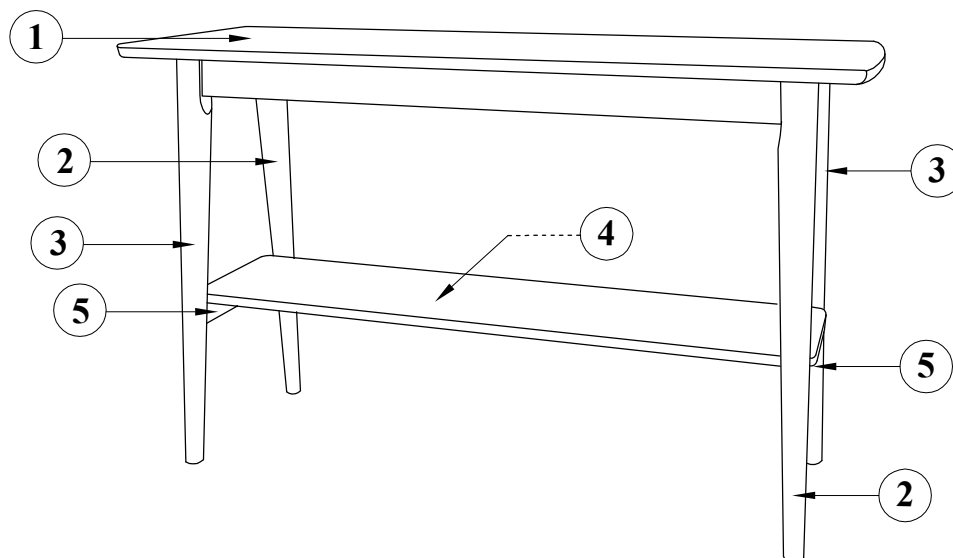





**COMPLETE ASSEMBLY**

THANK YOU FOR PURCHASING THIS QUALITY PRODUCT. BE SURE TO CHECK ALL PACKING MATERIAL CAREFULLY FOR SMALL PARTS WHICH MAY HAVE COME LOOSE INSIDE THE CARTON DURING THE SHIPMENT. SEPARATE, IDENTIFY AND COUNT ALL PARTS AND METAL HARDWARE, COMPARE WITH THE PARTS LISTS BELOW TO BE SURE ALL PARTS ARE PRESENT.

PART LIST

CODE	DESCRIPTION	QTY.
1	TABLE TOP	1 PC
2	TABLE LEG (RIGHT)	2 PCS
3	TABLE LEG (LEFT)	2 PCS
4	SHELF	1 PC
5	SIDE PANEL	2 PCS

HARDWARE LIST

CODE	DESCRIPTION	QTY.
A	 M4 X 110 MM ALLEN KEY	1 PC
B	 JCBC BOLT M6 X 60MM	8 PCS
C	 JCBC BOLT M6 X 50MM	4 PCS
D	 JCBC BOLT M6 X 30MM	4 PCS
E	 SPRING WASHER 1/4"	16 PCS
F	 FLAT WASHER M6 X 13MM	8 PCS
G	 FLAT WASHER 5/16"	8 PCS

ASSEMBLY INSTRUCTIONS
MODEL : TLF-1718
FCSCYAWM220905WN

R&D-YAW-AI

STEP 1

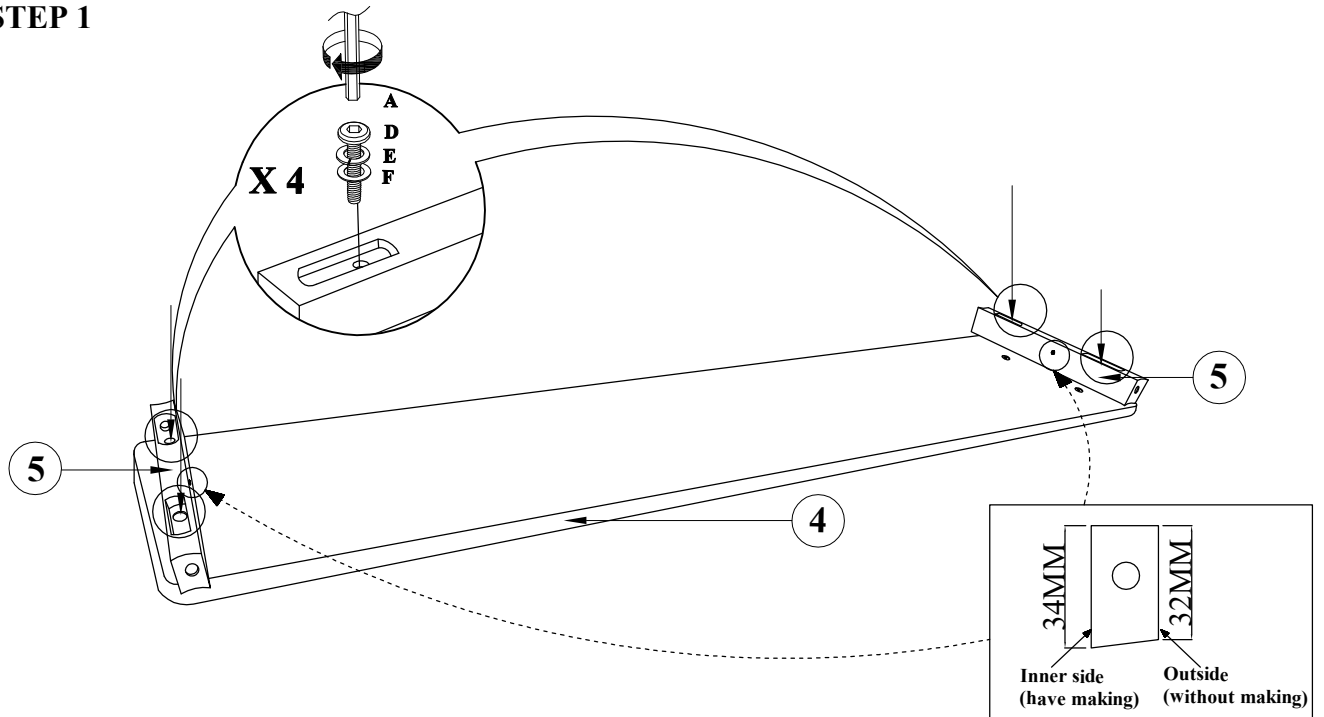

Attention! be careful before attach side panel position to shelf.

STEP 2

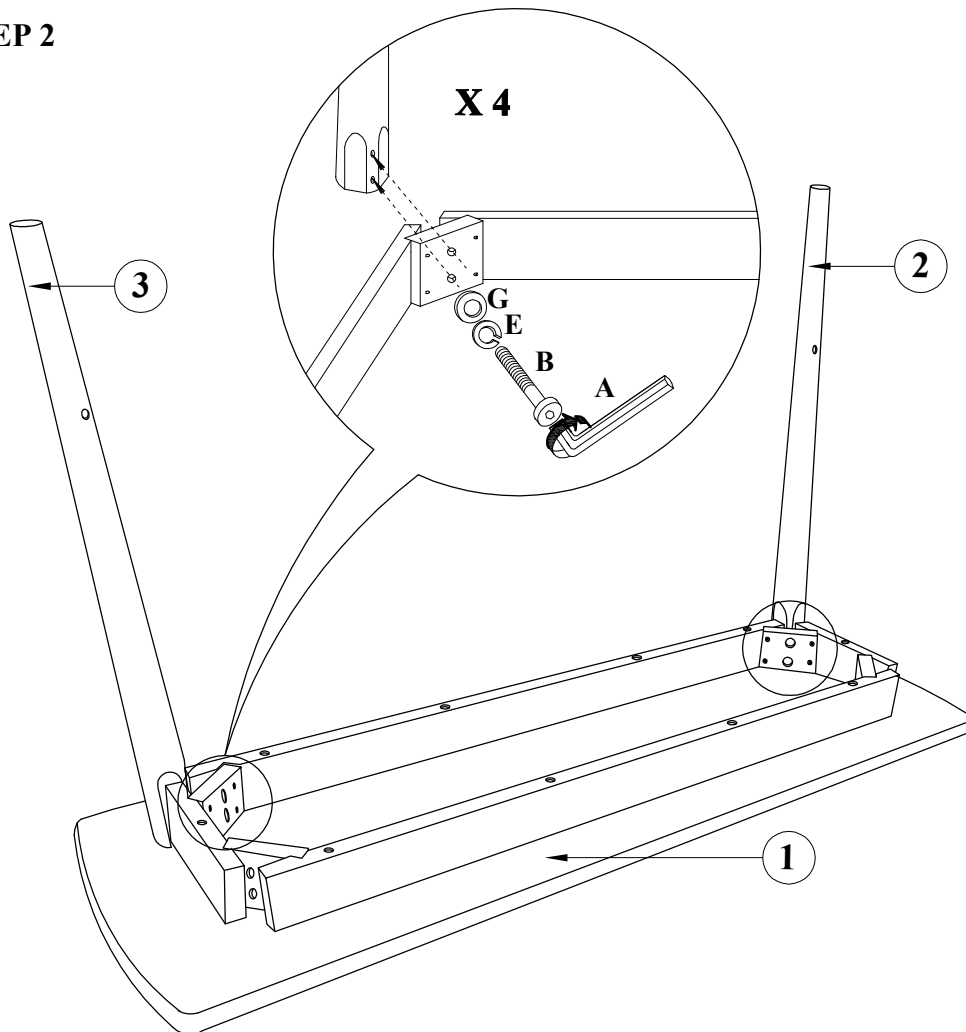

ASSEMBLY INSTRUCTIONS
MODEL : TLF-1718
FCSCYAWM220905WN

R&D-YAW-AI

STEP 3

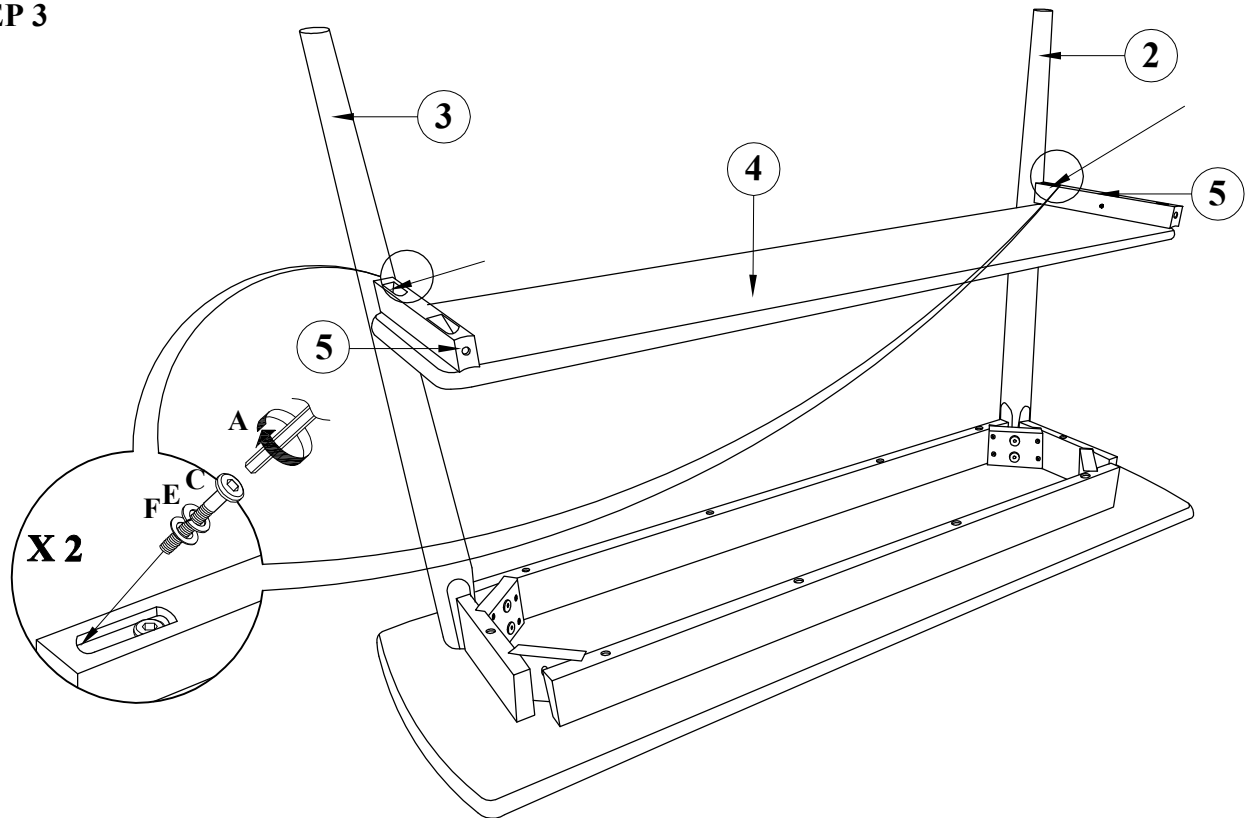

STEP 4

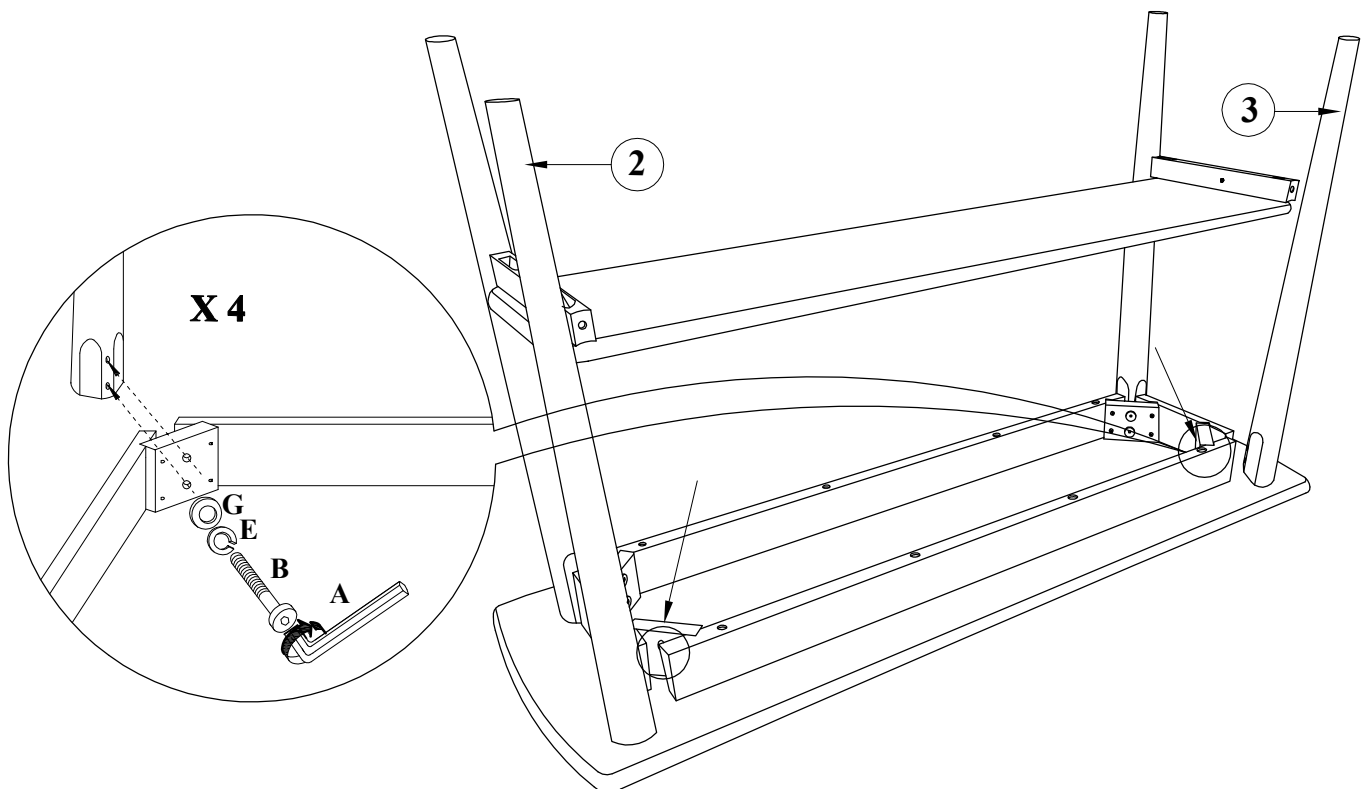

ASSEMBLY INSTRUCTIONS

MODEL : TLF-1718

FCSCYAWM220905WN

R&D-YAW-AI

STEP 5

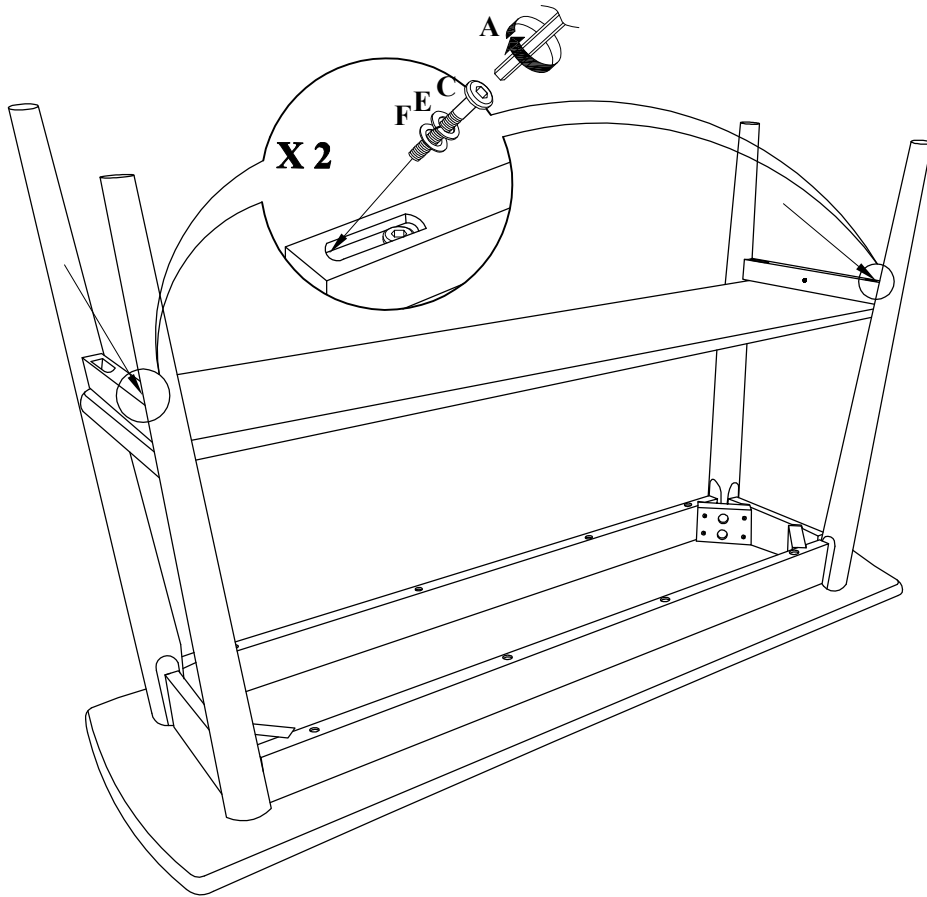

STEP 6

